

ITEM #	PART NUMBER	DESCRIPTION	QTY.	WEIGHT	LENGTH
1	FPT Tube Weldment	ASSEMBLY	1	81.55	
1.1	Table Top Brace	TUBE - 2" X 1"	4	1.28	7"
1.2	Leg	TUBE - 2" X 1"	4	4.14	23.71"
1.3	Leg Cross Brace	TUBE - 2" X 1"	4	5.49	31.61"
1.4	Table Top Inside	TUBE - 2" X 1"	4	3.28	19"
1.5	Table Top Outside	TUBE - 2" X 1"	4	6.20	35"
2	Lid	ASSEMBLY	1	14.57	
2.1	Lid Base	BENT PLATE - 3/16" X 1"	1	3.32	62.81"
2.2	Lid Handle	BENT BAR - 3/8" DIAM	1	0.23	7.25"
2.3	Fire Mesh Cloth	FIREPROOF SCREEN	1	9.27	
2.4	Screen Support	BENT PLATE - 3/16" X 1"	2	0.88	39.5"
3	Firepit Foot	PLATE - 1/8"	4	0.15	
4	Pit Side	BENT PLATE - 1/8"	3	4.21	
5	Pit Bottom	BENT PLATE - 1/8"	1	7.31	
6	Table Top	BENT PLATE - 1/8"	4	11.58	
7	Ash Dump Door	BENT PLATE - 3/16"	1	3.02	
8	Dump Door Bracket	PLATE - 1/4"	4	0.14	

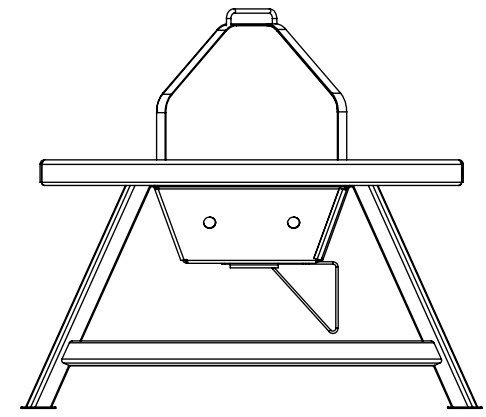

Page 1 of 10
 VERIFIED:

PROPRIETARY AND CONFIDENTIAL
 THE INFORMATION CONTAINED IN THIS DRAWING IS THE SOLE PROPERTY OF BUNDA 3-DIMENSIONAL DRAFTING & DESIGN. ANY REPRODUCTION WITHOUT WRITTEN PERMISSION IS PROHIBITED.

ALL DIMENSIONS ARE IN INCHES UNLESS OTHERWISE NOTED

TOLERANCES:
 FRACTIONAL: ± 1/32"
 ANGULAR: ± 1 Degree
 TWO PLACE DECIMAL: ± .01"
 THREE PLACE DECIMAL: ± .001"

	NAME	DATE
DRAWN	KKB	1/16/2011
CHECKED		

COMPLETE ASSEMBLY
 WEIGHT: 166.59 lb

SCALE: 1:16
 DO NOT SCALE DRAWING

B3D

Firepit Table

Firepit Table



THIS DRAWING PRINTED ON: 1/23/2011

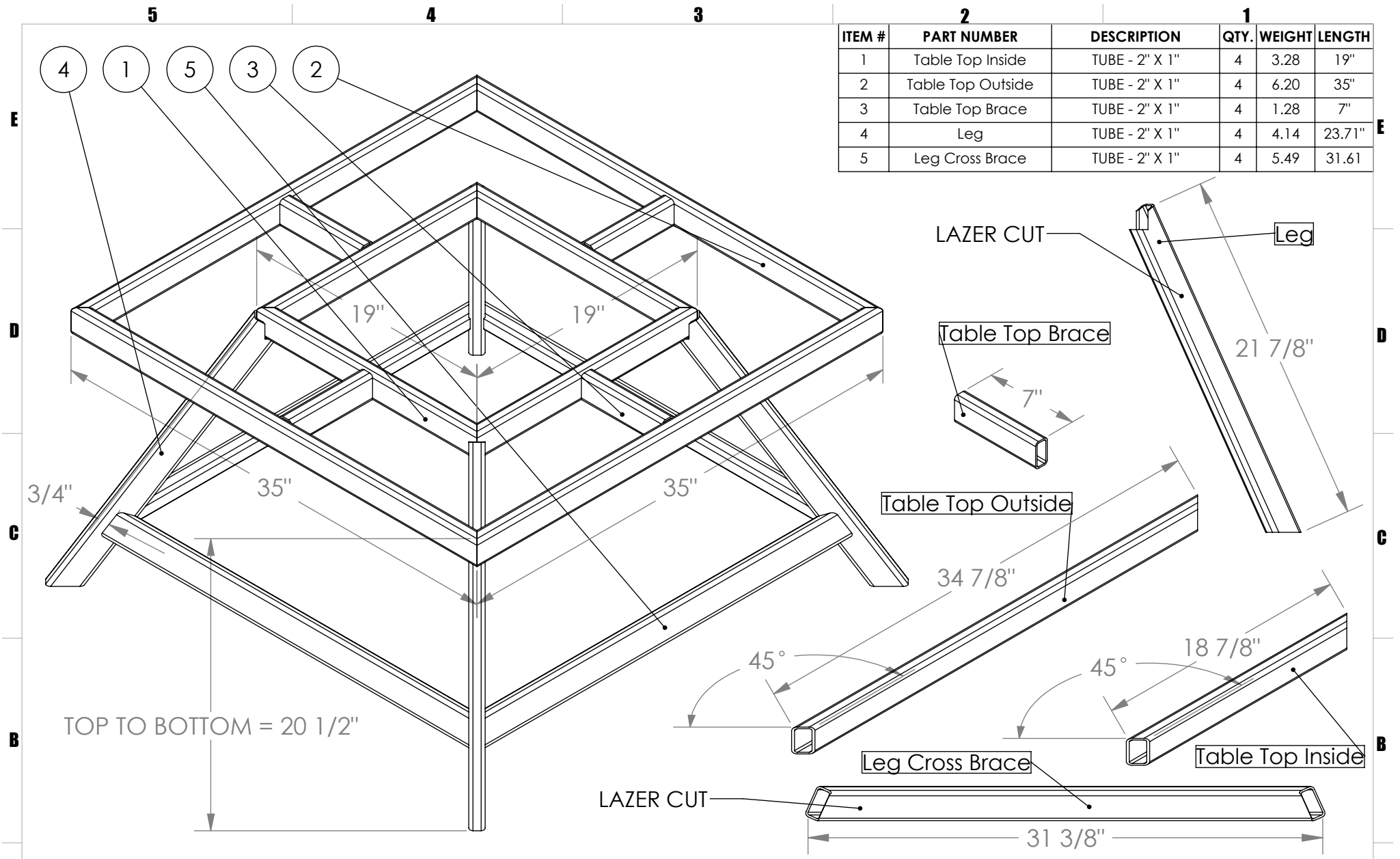

ITEM #	PART NUMBER	DESCRIPTION	QTY.	WEIGHT	LENGTH
1	Table Top Inside	TUBE - 2" X 1"	4	3.28	19"
2	Table Top Outside	TUBE - 2" X 1"	4	6.20	35"
3	Table Top Brace	TUBE - 2" X 1"	4	1.28	7"
4	Leg	TUBE - 2" X 1"	4	4.14	23.71"
5	Leg Cross Brace	TUBE - 2" X 1"	4	5.49	31.61"

Page 2 of 10
 VERIFIED: ?



THIS DRAWING PRINTED ON: 1/23/2011

PROPRIETARY AND CONFIDENTIAL
 THE INFORMATION CONTAINED IN THIS DRAWING IS THE SOLE PROPERTY OF BUNDA 3-DIMENSIONAL DRAFTING & DESIGN. ANY REPRODUCTION WITHOUT WRITTEN PERMISSION IS PROHIBITED.

ALL DIMENSIONS ARE IN INCHES UNLESS OTHERWISE NOTED

TOLERANCES:
 FRACTIONAL: ± 1/32"
 ANGULAR: ± 1 Degree
 TWO PLACE DECIMAL: ± .01"
 THREE PLACE DECIMAL: ± .001"

	NAME	DATE
DRAWN	KKB	1/16/2011
CHECKED		
FP Table Structure Weldment		
WEIGHT: 81.55 lb		
SCALE: 1:8		
DO NOT SCALE DRAWING		

B3D

Firepit Table

ASSEMBLY

5

4

3

2

1

E

E

D

D

C

C

B

B

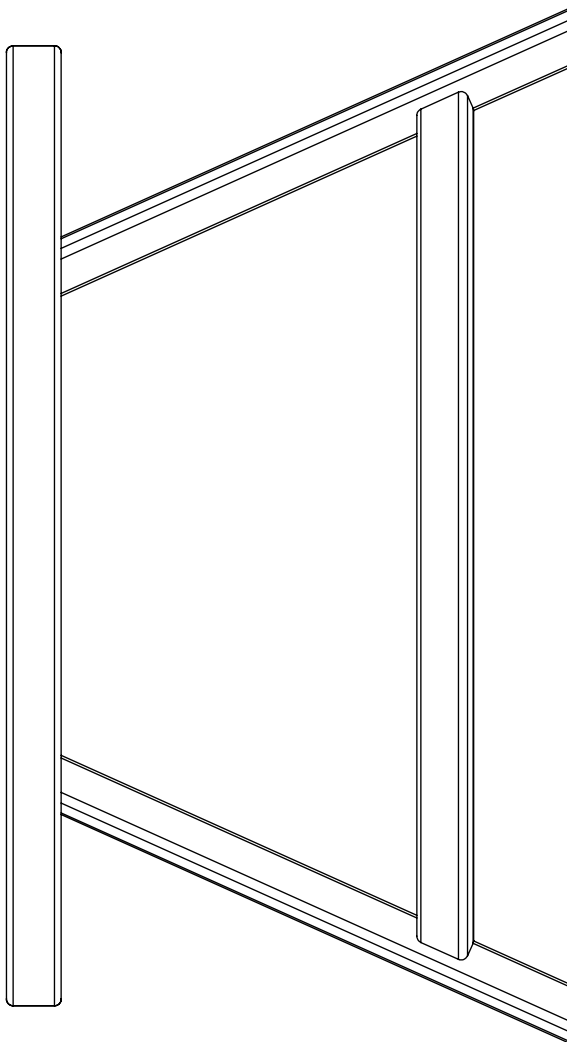

SIDE VIEW

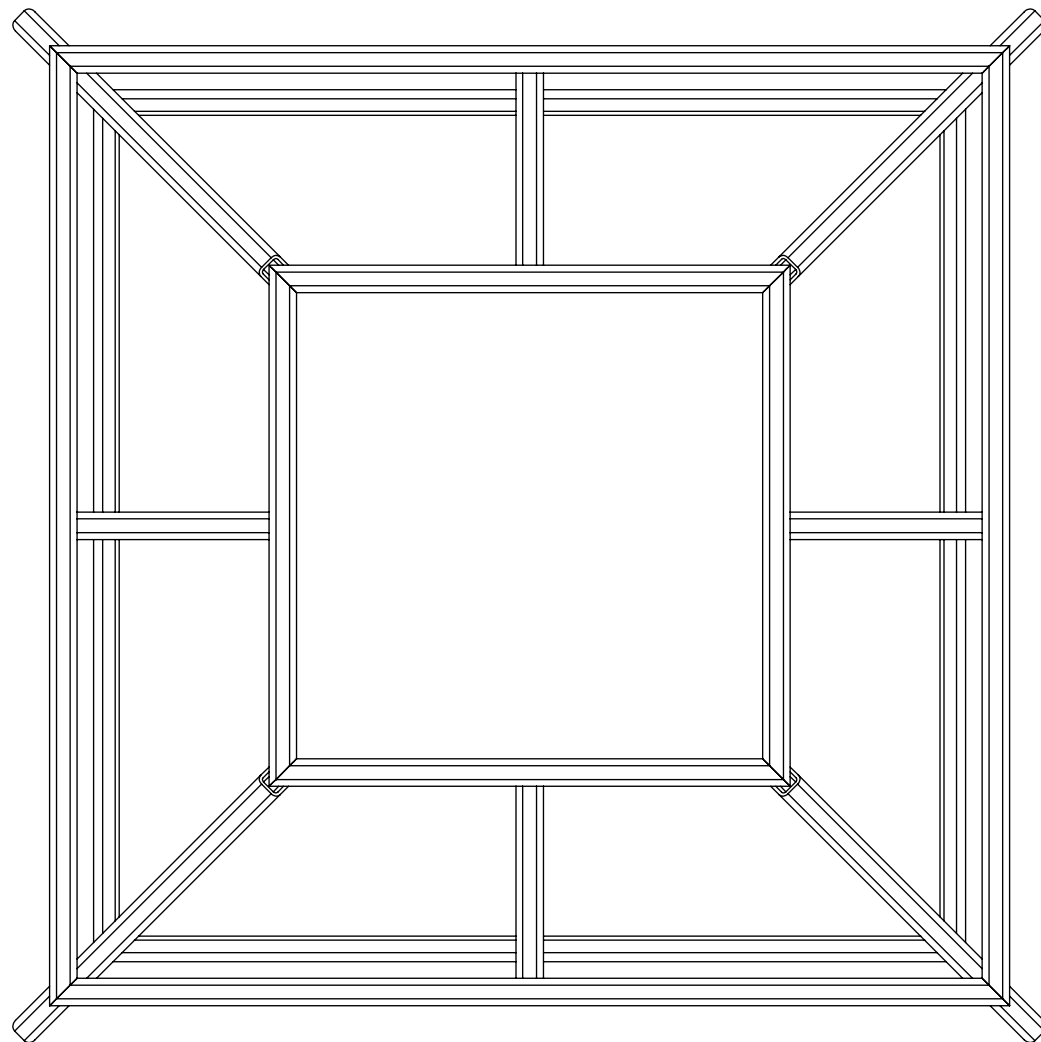

TOP VIEW

Page 3 of 10

VERIFIED:

PROPRIETARY AND CONFIDENTIAL

THE INFORMATION CONTAINED IN THIS DRAWING IS THE SOLE PROPERTY OF BUNDA 3-DIMENSIONAL DRAFTING & DESIGN. ANY REPRODUCTION WITHOUT WRITTEN PERMISSION IS PROHIBITED.

ALL DIMENSIONS ARE IN INCHES UNLESS OTHERWISE NOTED

TOLERANCES:

FRACTIONAL: ± 1/32"
ANGULAR: ± 1 Degree
TWO PLACE DECIMAL: ± .01"
THREE PLACE DECIMAL: ± .001"

NAME

KKB

DATE

1/16/2011

DRAWN

CHECKED

WEIGHT: lb

SCALE: 1:7

DO NOT SCALE DRAWING

B3D

Firepit Table

Firepit Table Weldment



THIS DRAWING PRINTED ON: 1/23/2011

5

4

3

2

1

A

A

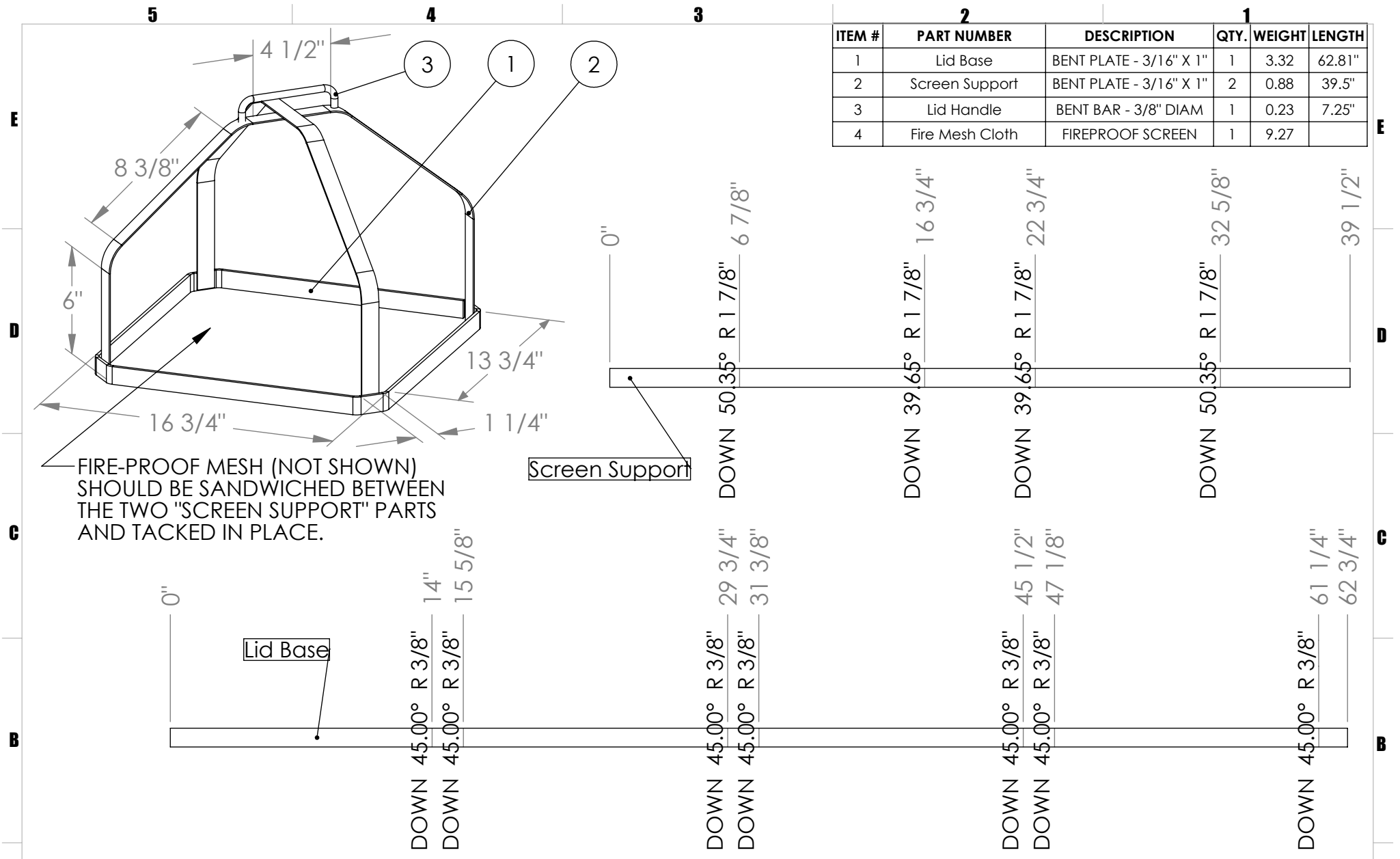

ITEM #	PART NUMBER	DESCRIPTION	QTY.	WEIGHT	LENGTH
1	Lid Base	BENT PLATE - 3/16" X 1"	1	3.32	62.81"
2	Screen Support	BENT PLATE - 3/16" X 1"	2	0.88	39.5"
3	Lid Handle	BENT BAR - 3/8" DIAM	1	0.23	7.25"
4	Fire Mesh Cloth	FIREPROOF SCREEN	1	9.27	

FIRE-PROOF MESH (NOT SHOWN) SHOULD BE SANDWICHED BETWEEN THE TWO "SCREEN SUPPORT" PARTS AND TACKED IN PLACE.

<p>Page 4 of 10</p> <p>VERIFIED:</p>  <p>THIS DRAWING PRINTED ON: 1/23/2011</p>	<p>PROPRIETARY AND CONFIDENTIAL</p> <p>THE INFORMATION CONTAINED IN THIS DRAWING IS THE SOLE PROPERTY OF BUNDA 3-DIMENSIONAL DRAFTING & DESIGN. ANY REPRODUCTION WITHOUT WRITTEN PERMISSION IS PROHIBITED.</p> <p>ALL DIMENSIONS ARE IN INCHES UNLESS OTHERWISE NOTED</p> <p>TOLERANCES: FRACTIONAL: ± 1/32" ANGULAR: ± 1 Degree TWO PLACE DECIMAL: ± .01" THREE PLACE DECIMAL: ± .001"</p>	<p>NAME</p> <p>DATE</p>	<p>B3D</p> <p>Firepit Table</p> <p>ASSEMBLY</p>
		<p>DRAWN</p> <p>CHECKED</p>	
		<p>WEIGHT: 14.57 lb</p>	
		<p>SCALE: 1:7</p> <p>DO NOT SCALE DRAWING</p>	

5

4

3

2

1

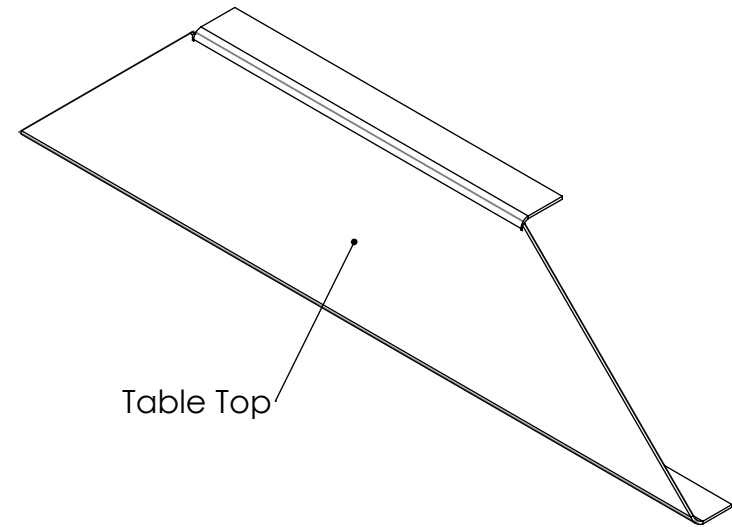
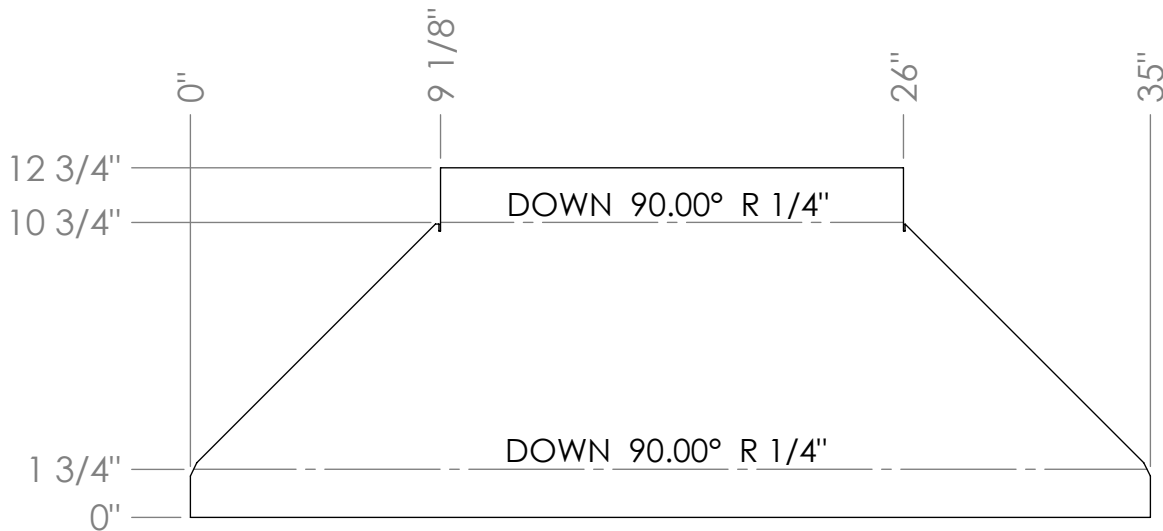
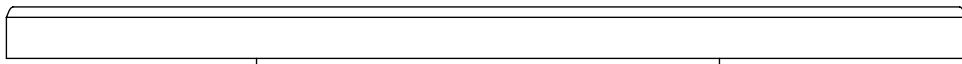
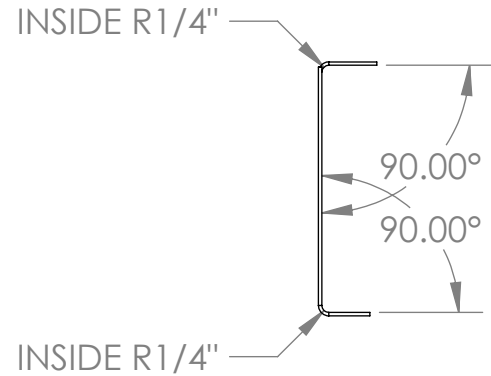
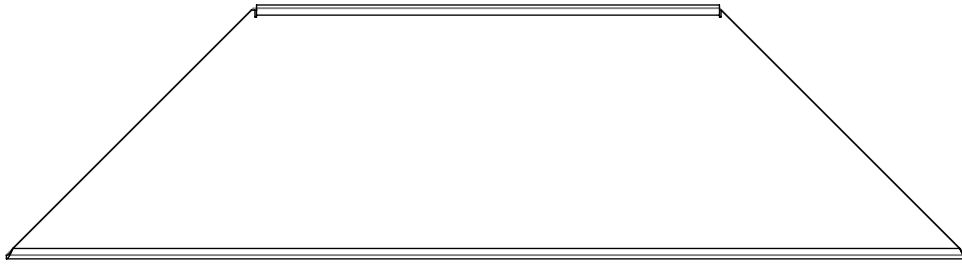

Page 5 of 10

VERIFIED:

PROPRIETARY AND CONFIDENTIAL
 THE INFORMATION CONTAINED IN THIS DRAWING IS THE SOLE PROPERTY OF BUNDA 3-DIMENSIONAL DRAFTING & DESIGN. ANY REPRODUCTION WITHOUT WRITTEN PERMISSION IS PROHIBITED.

ALL DIMENSIONS ARE IN INCHES UNLESS OTHERWISE NOTED

TOLERANCES:
 FRACTIONAL: $\pm 1/32"$
 ANGULAR: ± 1 Degree
 TWO PLACE DECIMAL: $\pm .01"$
 THREE PLACE DECIMAL: $\pm .001"$

	NAME	DATE
DRAWN	KKB	1/16/2011
CHECKED		

WEIGHT: 11.58 lb

SCALE: 1:7
DO NOT SCALE DRAWING

B3D

Firepit Table

BENT PLATE - 1/8"



THIS DRAWING PRINTED ON: 1/23/2011

5

4

3

2

1

5 4 3 2 1

Page 6 of 10

VERIFIED:

PROPRIETARY AND CONFIDENTIAL
 THE INFORMATION CONTAINED IN THIS DRAWING IS THE SOLE PROPERTY OF BUNDA 3-DIMENSIONAL DRAFTING & DESIGN. ANY REPRODUCTION WITHOUT WRITTEN PERMISSION IS PROHIBITED.

ALL DIMENSIONS ARE IN INCHES UNLESS OTHERWISE NOTED

TOLERANCES:
 FRACTIONAL: ± 1/32"
 ANGULAR: ± 1 Degree
 TWO PLACE DECIMAL: ± .01"
 THREE PLACE DECIMAL: ± .001"

	NAME	DATE
DRAWN	KKB	1/16/2011
CHECKED		

WEIGHT: 4.21 lb

SCALE: 1:6
DO NOT SCALE DRAWING

B3D

Firepit Table

BENT PLATE - 1/8"

THIS DRAWING PRINTED ON: 1/23/2011

5 4 3 2 1

5

4

3

2

1

E

E

D

D

C

C

B

B

A

A

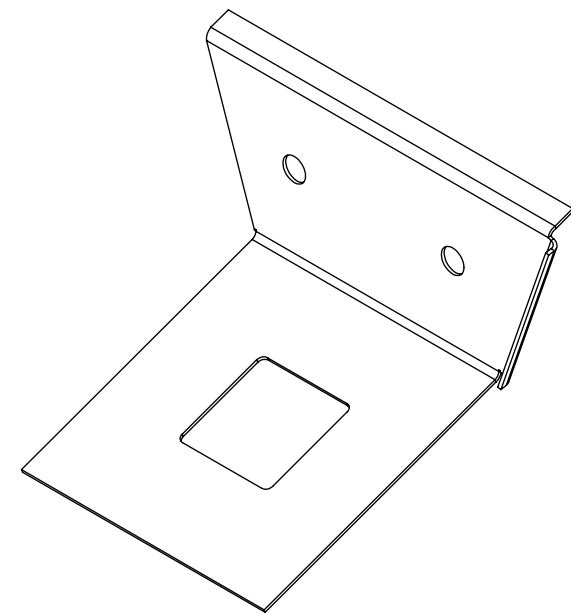
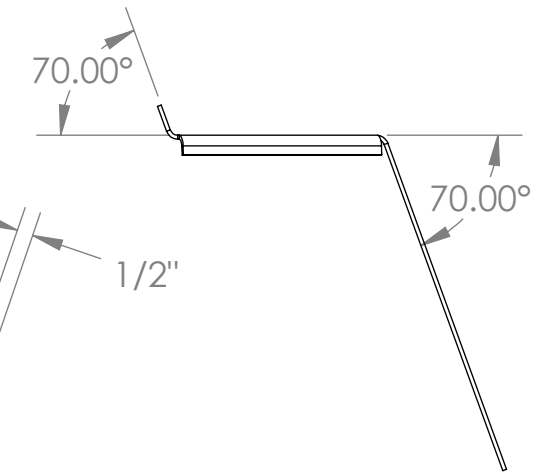
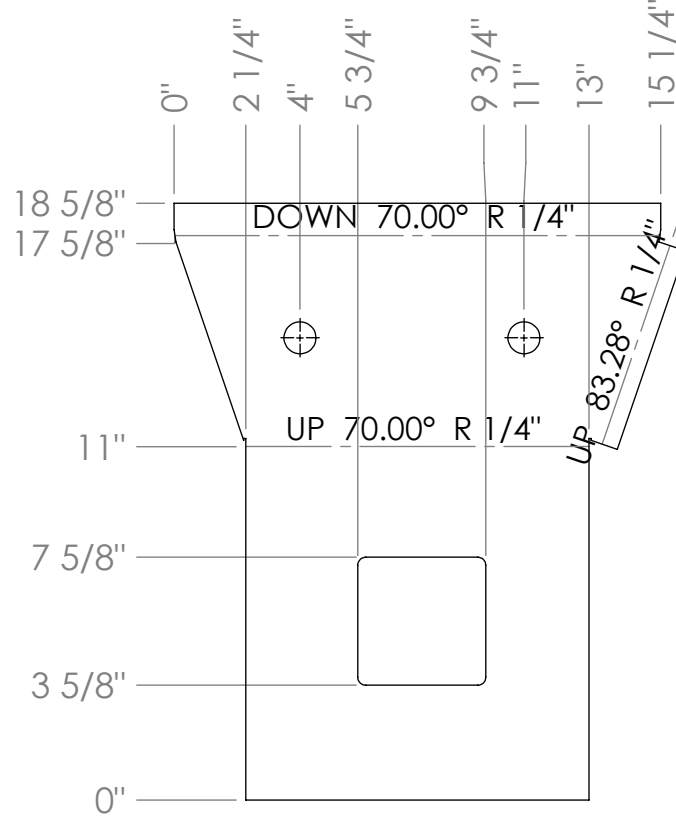
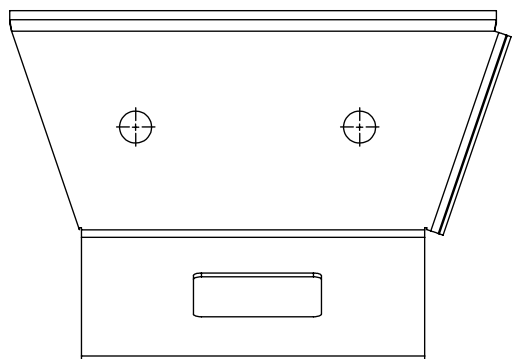
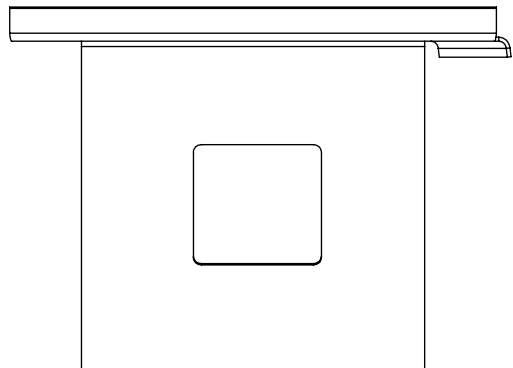

Page 7 of 10

VERIFIED:

PROPRIETARY AND CONFIDENTIAL

THE INFORMATION CONTAINED IN THIS DRAWING IS THE SOLE PROPERTY OF BUNDA 3-DIMENSIONAL DRAFTING & DESIGN. ANY REPRODUCTION WITHOUT WRITTEN PERMISSION IS PROHIBITED.

ALL DIMENSIONS ARE IN INCHES UNLESS OTHERWISE NOTED

TOLERANCES:

FRACTIONAL: ± 1/32"
ANGULAR: ± 1 Degree
TWO PLACE DECIMAL: ± .01"
THREE PLACE DECIMAL: ± .001"

NAME

KKB

DATE

1/16/2011

DRAWN

CHECKED

B3D

Firepit Table

WEIGHT: 7.31 lb

SCALE: 1:6
DO NOT SCALE DRAWING

BENT PLATE - 1/8"

THIS DRAWING PRINTED ON: 1/23/2011

5

4

3

2

1



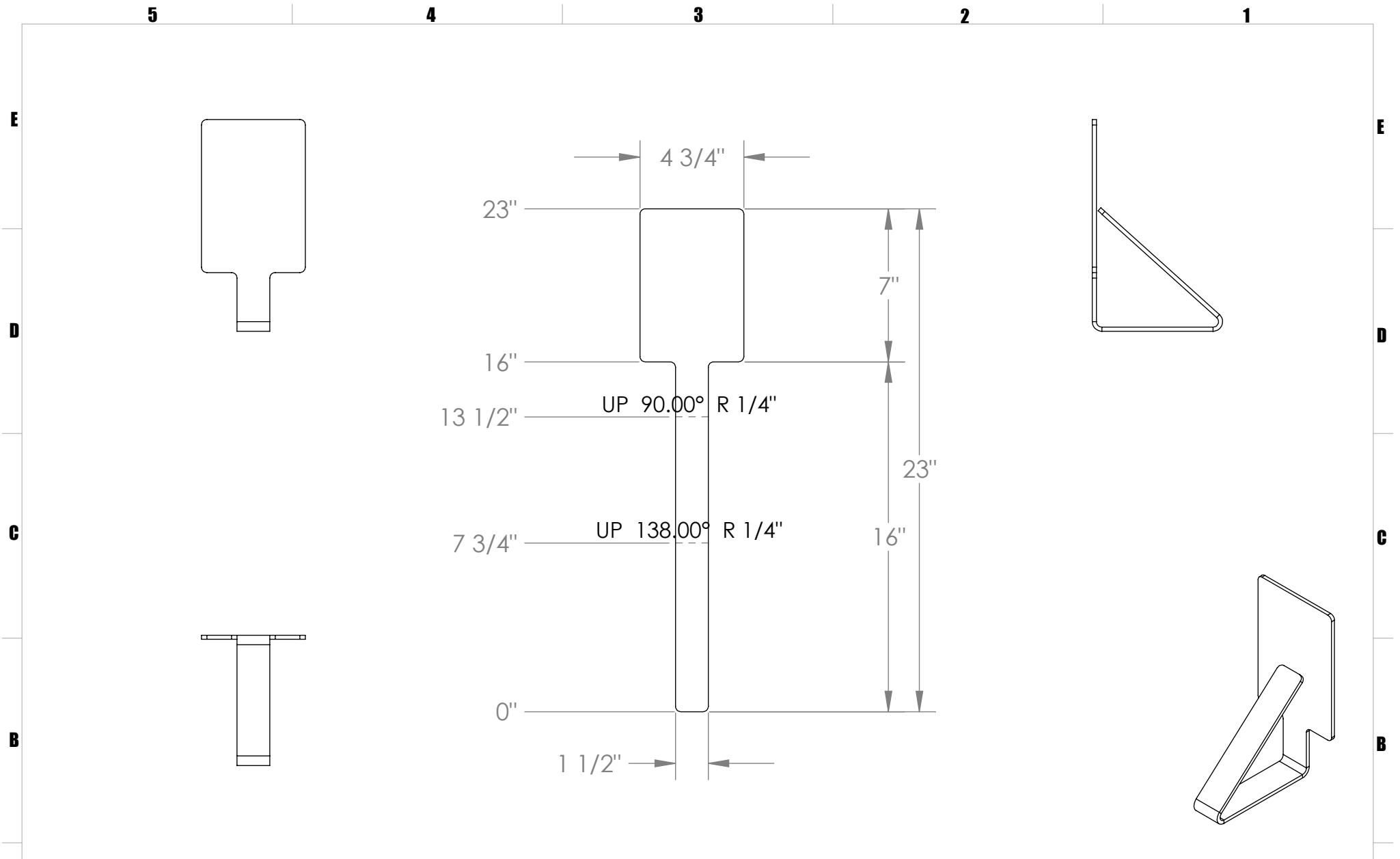

Page 8 of 10

VERIFIED:

PROPRIETARY AND CONFIDENTIAL
 THE INFORMATION CONTAINED IN THIS DRAWING IS THE SOLE PROPERTY OF BUNDA 3-DIMENSIONAL DRAFTING & DESIGN. ANY REPRODUCTION WITHOUT WRITTEN PERMISSION IS PROHIBITED.

ALL DIMENSIONS ARE IN INCHES UNLESS OTHERWISE NOTED

TOLERANCES:
 FRACTIONAL: ± 1/32"
 ANGULAR: ± 1 Degree
 TWO PLACE DECIMAL: ± .01"
 THREE PLACE DECIMAL: ± .001"

	NAME	DATE
DRAWN	KKB	1/16/2011
CHECKED		

WEIGHT: 3.02 lb

SCALE: 1:6
DO NOT SCALE DRAWING

B3D

Firepit Table

BENT PLATE - 3/16"



THIS DRAWING PRINTED ON: 1/23/2011

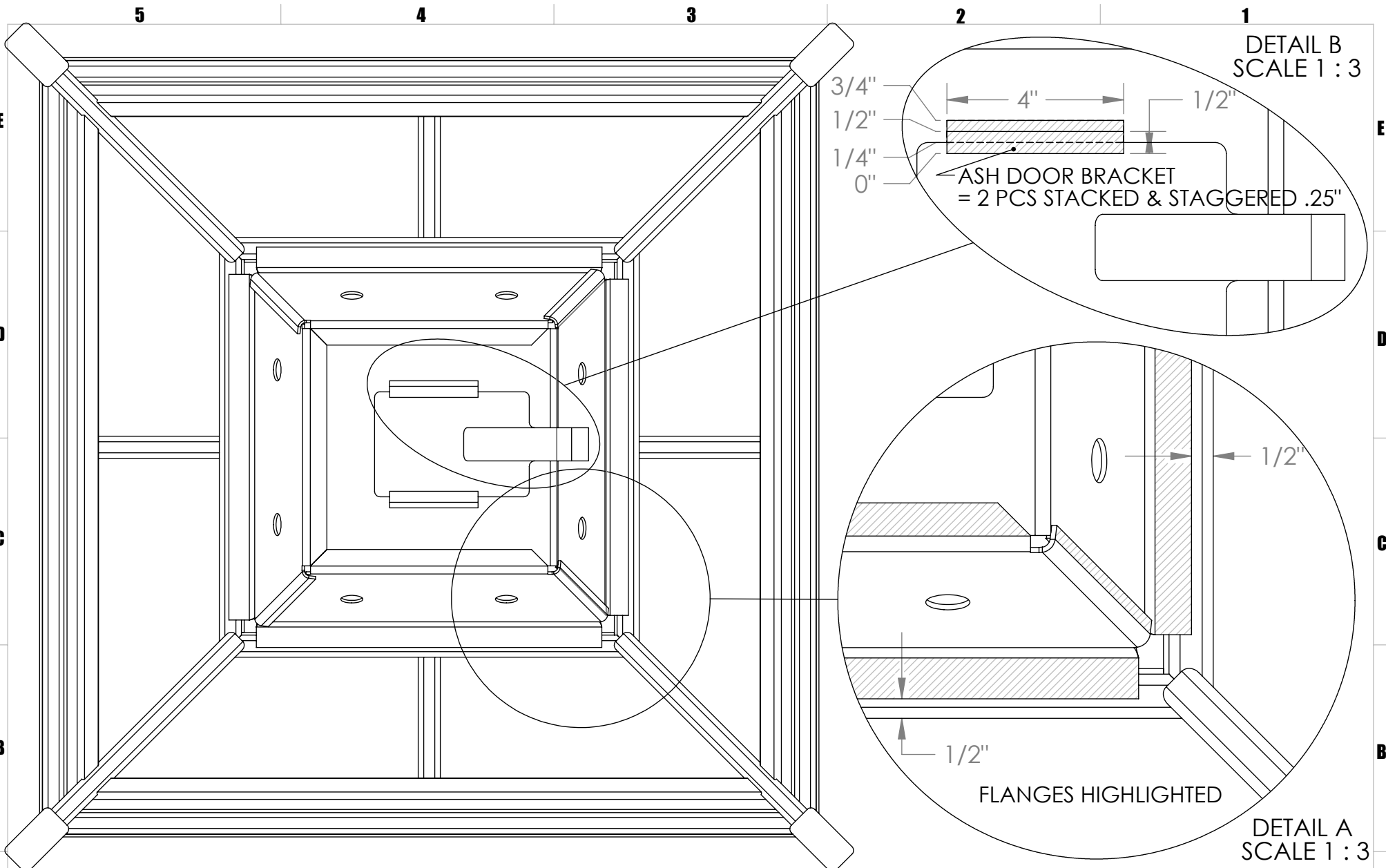

DETAIL B
SCALE 1 : 3

DETAIL A
SCALE 1 : 3

Page 9 of 10

VERIFIED:

PROPRIETARY AND CONFIDENTIAL

THE INFORMATION CONTAINED IN THIS DRAWING IS THE SOLE PROPERTY OF BUNDA 3-DIMENSIONAL DRAFTING & DESIGN. ANY REPRODUCTION WITHOUT WRITTEN PERMISSION IS PROHIBITED.

ALL DIMENSIONS ARE IN INCHES UNLESS OTHERWISE NOTED

TOLERANCES:

FRACTIONAL: $\pm 1/32"$
 ANGULAR: ± 1 Degree
 TWO PLACE DECIMAL: $\pm .01"$
 THREE PLACE DECIMAL: $\pm .001"$

	NAME	DATE
DRAWN	KKB	1/16/2011
CHECKED		

COMPLETE ASSEMBLY
WEIGHT: 166.59 lb

SCALE: 1:6
DO NOT SCALE DRAWING

B3D

Firepit Table

Firepit Table



THIS DRAWING PRINTED ON: 1/23/2011

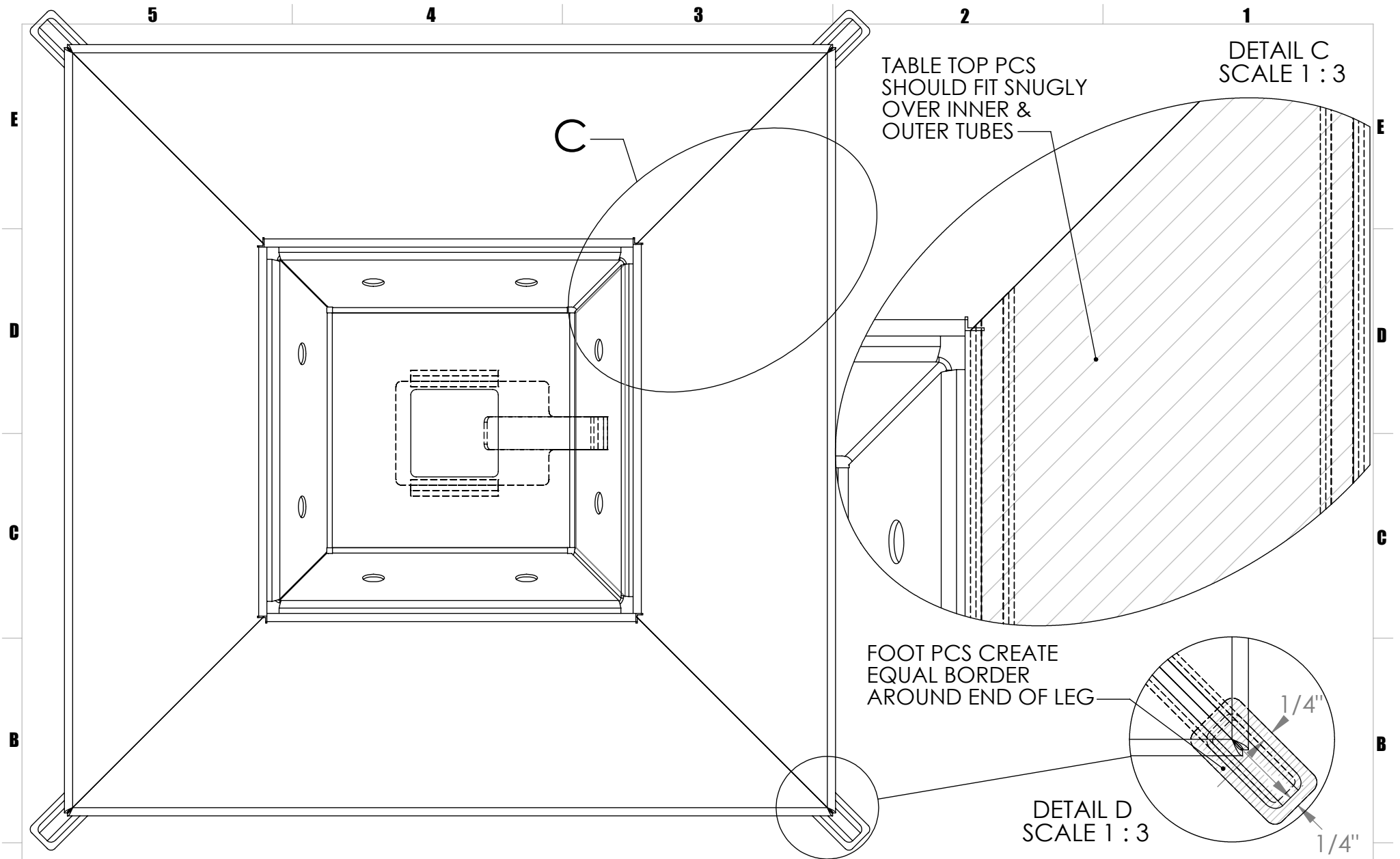

Page 10 of 10

VERIFIED:

PROPRIETARY AND CONFIDENTIAL

THE INFORMATION CONTAINED IN THIS DRAWING IS THE SOLE PROPERTY OF BUNDA 3-DIMENSIONAL DRAFTING & DESIGN. ANY REPRODUCTION WITHOUT WRITTEN PERMISSION IS PROHIBITED.

ALL DIMENSIONS ARE IN INCHES UNLESS OTHERWISE NOTED

TOLERANCES:

FRACTIONAL: $\pm 1/32"$
 ANGULAR: ± 1 Degree
 TWO PLACE DECIMAL: $\pm .01"$
 THREE PLACE DECIMAL: $\pm .001"$

	NAME	DATE
DRAWN	KKB	1/16/2011
CHECKED		

COMPLETE ASSEMBLY
 WEIGHT: 166.59 lb

SCALE: 1:6
DO NOT SCALE DRAWING

B3D

Firepit Table

Firepit Table



THIS DRAWING PRINTED ON: 1/23/2011

A

A

5

4

3

2

1