

E

D

C

B

A

[Dimension] mm
Dimension = inch

DESC	FILE#	RAIL100		
ASSEMBLY, FULL RAIL				
AUTH: KKB	DATE: 12/7/2010	WT(lbs): 156.38	SHEET 1 OF 8	



5

4

3

2

1

DETAIL A
SCALE 1 : 8

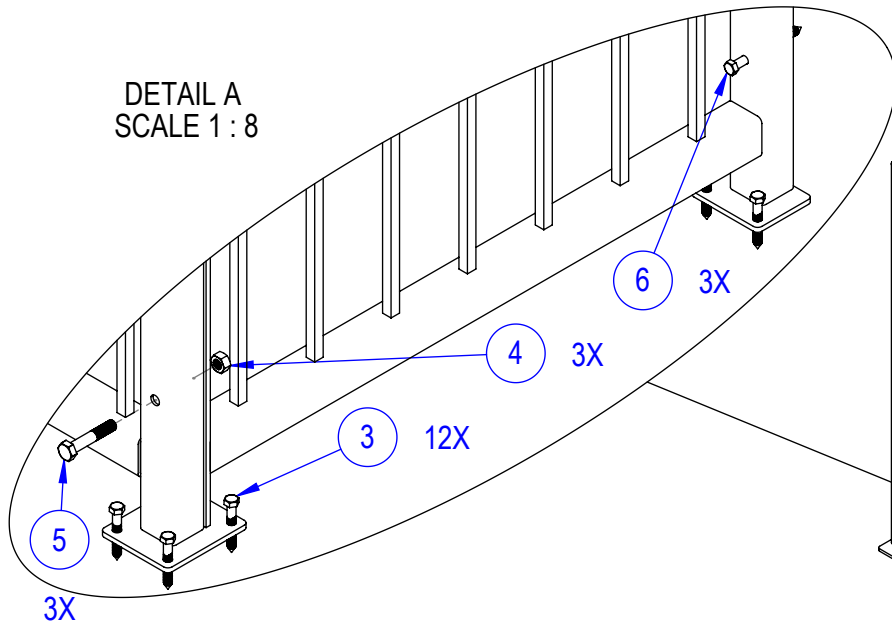

#	CAD FILE NAME	DESCRIPTION	QTY.	WEIGHT (LBS)
1	RAIL110	WELDMENT, LONG RAIL	1	105.83
2	RAIL120	WELDMENT, SHORT RAIL	1	48.73
3	LAG03750250	LAG SCREW, .375" X 2.50" HX ZD	12	0.08
4	NUT12175	NUT, M12-1.75 HX	3	0.03
5	BOLT1217565	BOLT, M12-1.75 X 65MM HX 8.8 ZD	3	0.15
6	LAG03750400	LAG SCREW, .375" X 4.00" HX ZD	3	0.12

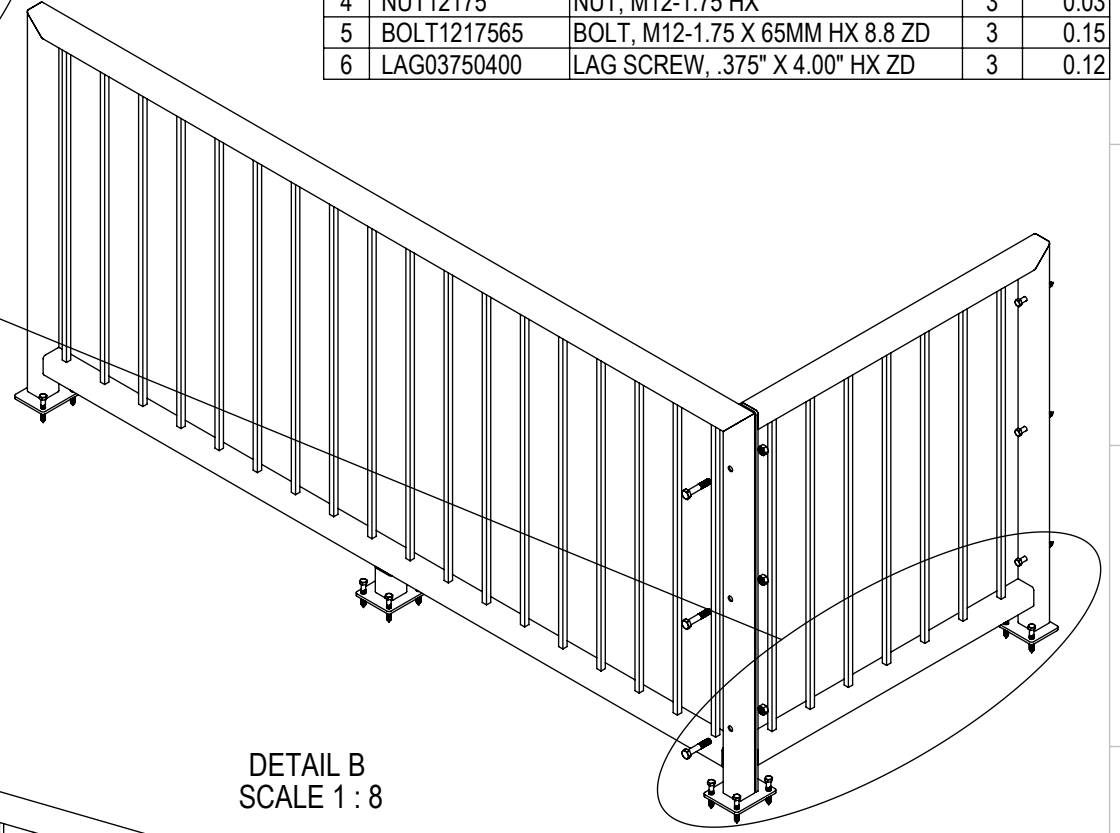

DETAIL B
SCALE 1 : 8

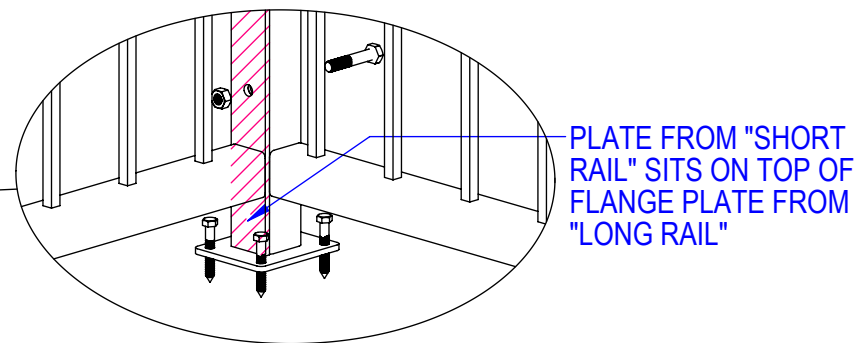
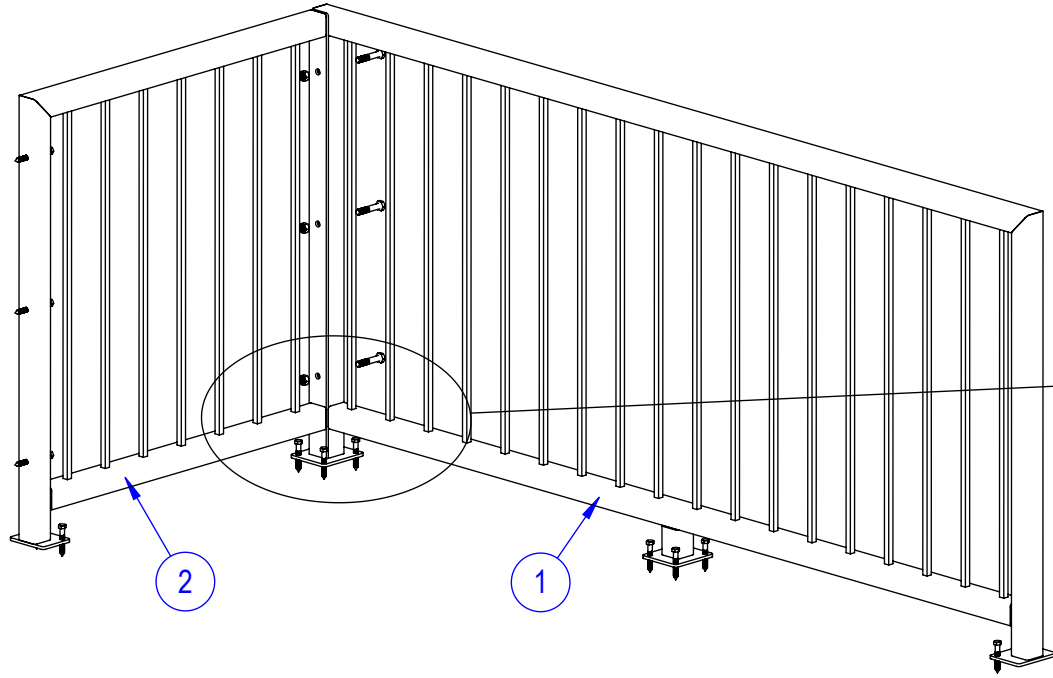

[Dimension] mm
Dimension = inch

FILE#	RAIL100			
DESC	ASSEMBLY, FULL RAIL			
AUTH: KKB	DATE: 12/7/2010	WT(lbs): 156.38	SHEET 2 OF 8	

#	CAD FILE NAME	DESCRIPTION	QTY.	MATERIAL (DIMENSIONAL)	WEIGHT (LBS)	LENGTH
1	RAIL111	RAIL FOOT FLANGE, CORNER	1	0.25	1.31	
2	RAIL112	RAIL FOOT FLANGE, START	1	0.25	1.10	
3	RAIL113	RAIL FOOT FLANGE, CENTER	1	0.25	1.24	
4	RAIL114	TUBE, 2 X 2 + BOLT HOLES	1	2 X 2 X .12 (11GA)	9.56	38.75"
5	RAIL115	TUBE, 2 X 2 UPRIGHT	1	2 X 2 X .12 (11GA)	9.61	38.75"
6	RAIL116	TUBE, 2 X 2 CENTER	1	2 X 2 X .12 (11GA)	0.64	2.5"
7	RAIL117	TUBE 2 X 2 HANDRAIL, LONG	1	2 X 2 X .12 (11GA)	20.87	86"
8	RAIL118	TUBE 2 X 2 STRINGER, LONG	1	2 X 2 X .12 (11GA)	20.36	82"
9	RAIL119	SQUARE BAR, .5" X .5" PICKET	18	FLAT .5 X .5	2.29	32.25"

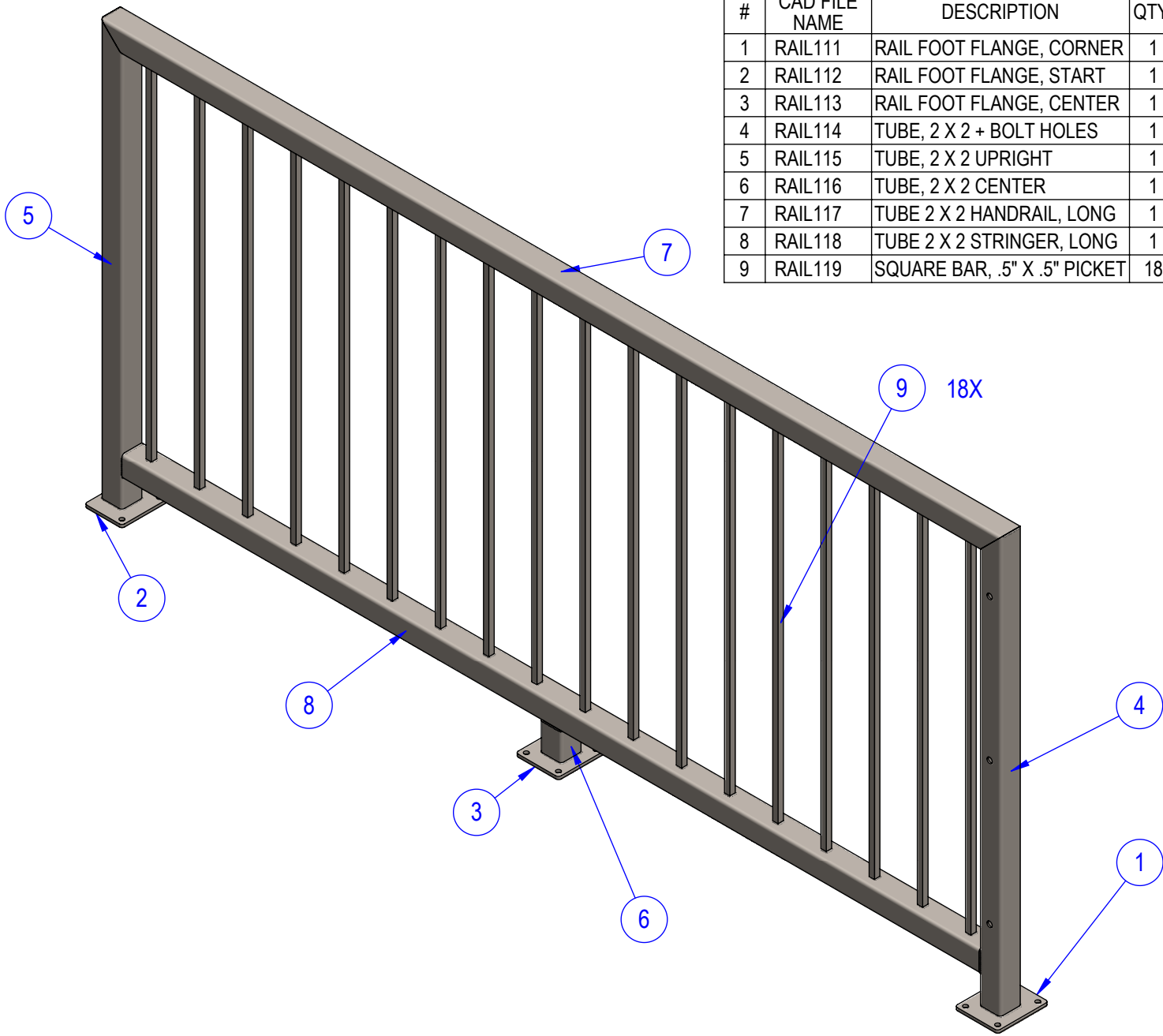

[Dimension] mm
Dimension = inch

FILE#	RAIL110			
DESC	WELDMENT, LONG RAIL			
AUTH: KKB	DATE: 12/7/2010	WT(lbs): 105.83	SHEET 3 OF 8	

5

4

3

2

1

E

D

C

B

A

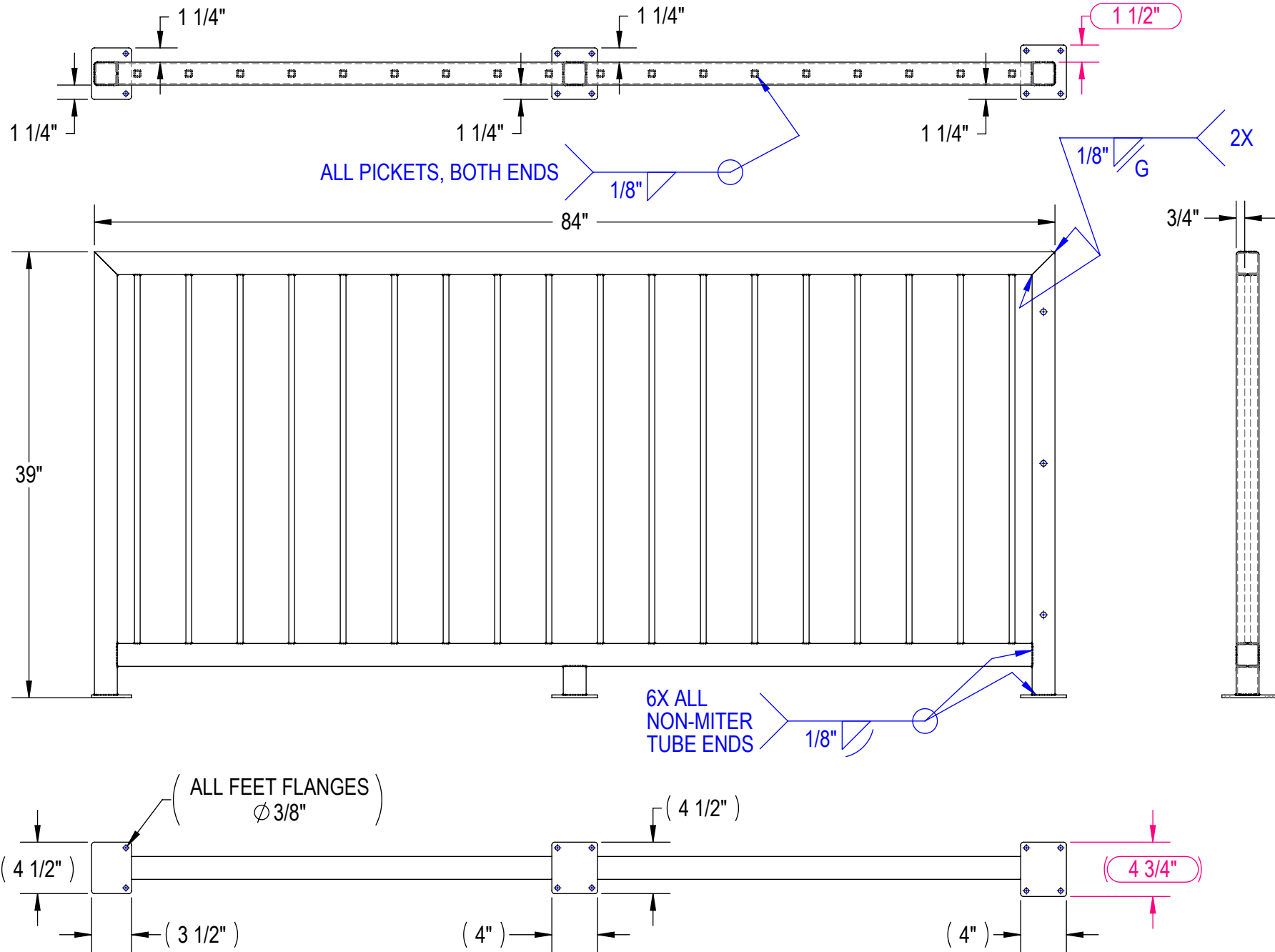

FILE#	RAIL110			
DESC	WELDMENT, LONG RAIL			
AUTH: KKB	DATE: 12/7/2010	WT(lbs): 105.83	SHEET 4 OF 8	

[Dimension] mm
Dimension = inch

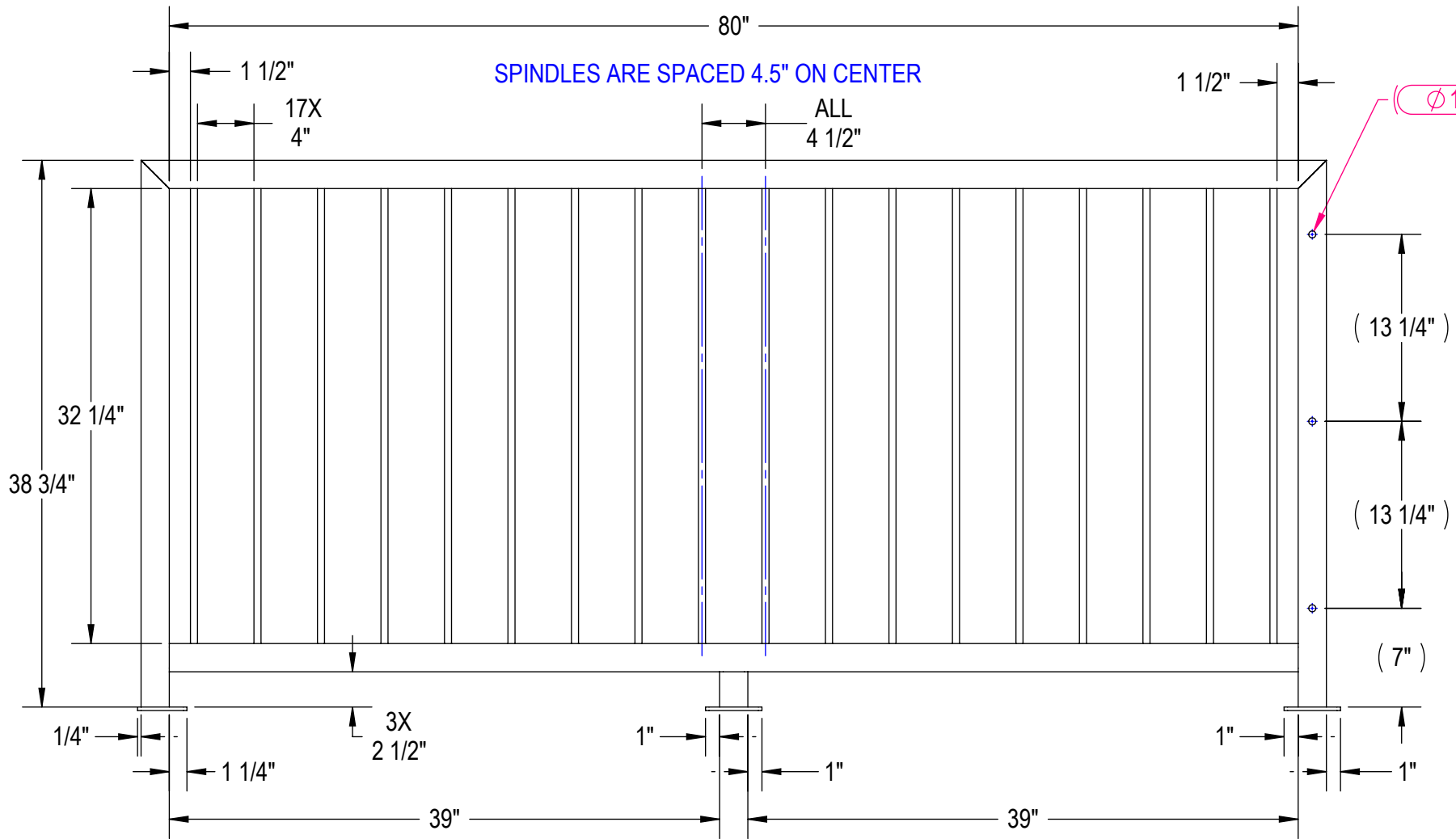

[Dimension] mm
Dimension = inch

FILE#	RAIL110			 B3D
DESC	WELDMNT, LONG RAIL			
AUTH: KKB	DATE: 12/7/2010	WT(lbs): 105.83	SHEET 5 OF 8	

5

4

3

2

1

E

D

C

B

A

#	CAD FILE NAME	DESCRIPTION	QTY.	MATERIAL (DIMENSIONAL)	WEIGHT (LBS)	LENGTH (FT)
1	RAIL124	TUBE 2 X 2 + HOLES, SHORT RAIL	1	2 X 2 X .12 (11GA)	9.58	38.75"
2	RAIL119	SQUARE BAR, .5" X .5" PICKET	7	FLAT .5 X .5	2.29	32.25"
3	RAIL121	RAIL FOOT FLANGE, SHORT, WALL END	1	0.25	0.90	
4	RAIL127	TUBE 2 X 2, UPRIGHT, SHORT RAIL	1	2 X 2 X .12 (11GA)	8.52	34.5"
5	RAIL128	TUBE 2 X 2, STRINGER, SHORT	1	2 X 2 X .12 (11GA)	8.27	38.75"
6	RAIL125	PLATE, 2" X .25 - END FLANGE, SHORT RAIL	1	0.25	5.45	38.75"

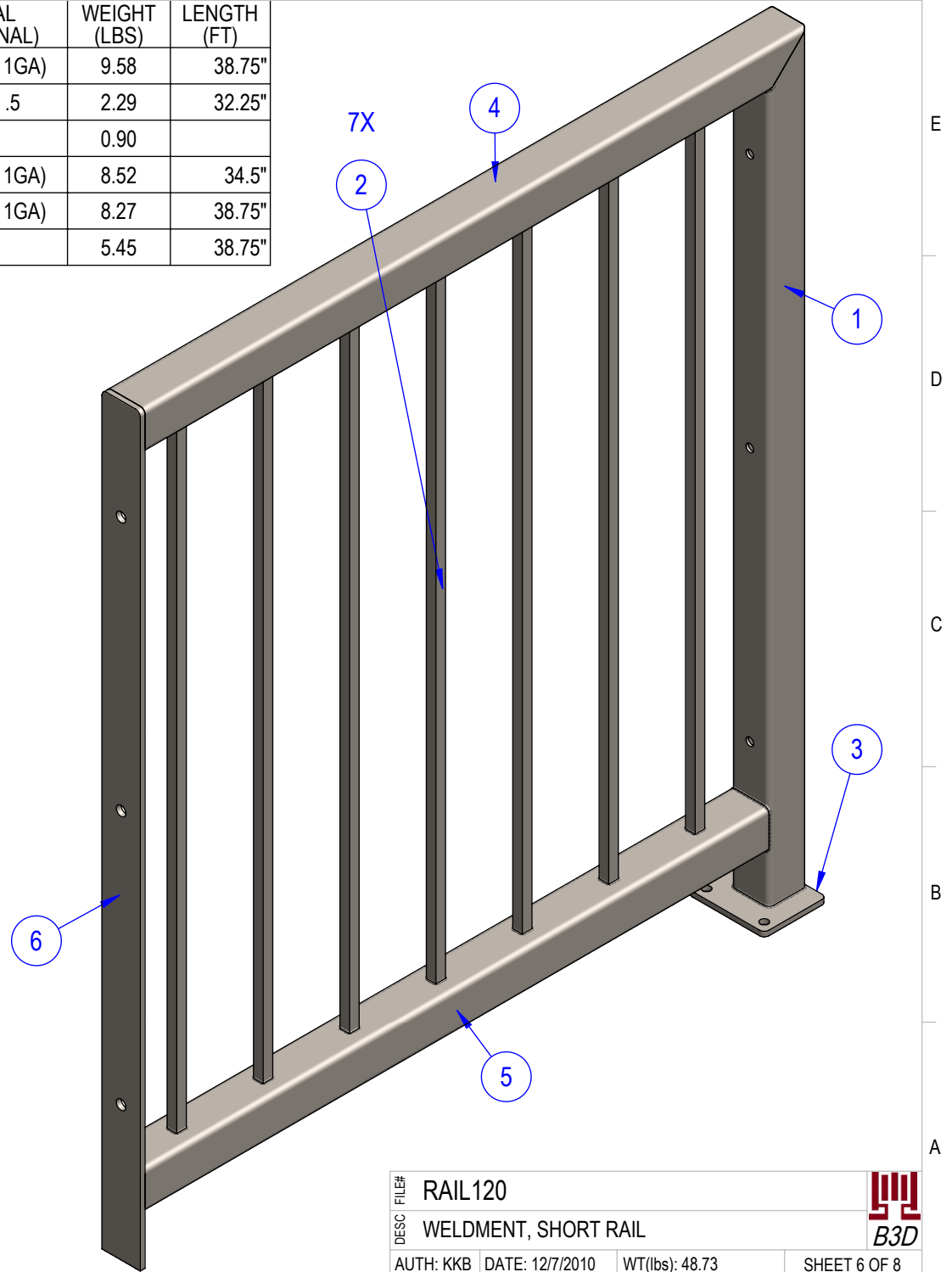

FILE#	RAIL120			
DESC	WELDMENT, SHORT RAIL			
AUTH: KKB	DATE: 12/7/2010	WT(lbs): 48.73	SHEET 6 OF 8	

5

4

3

2

1

A

B

C

D

E

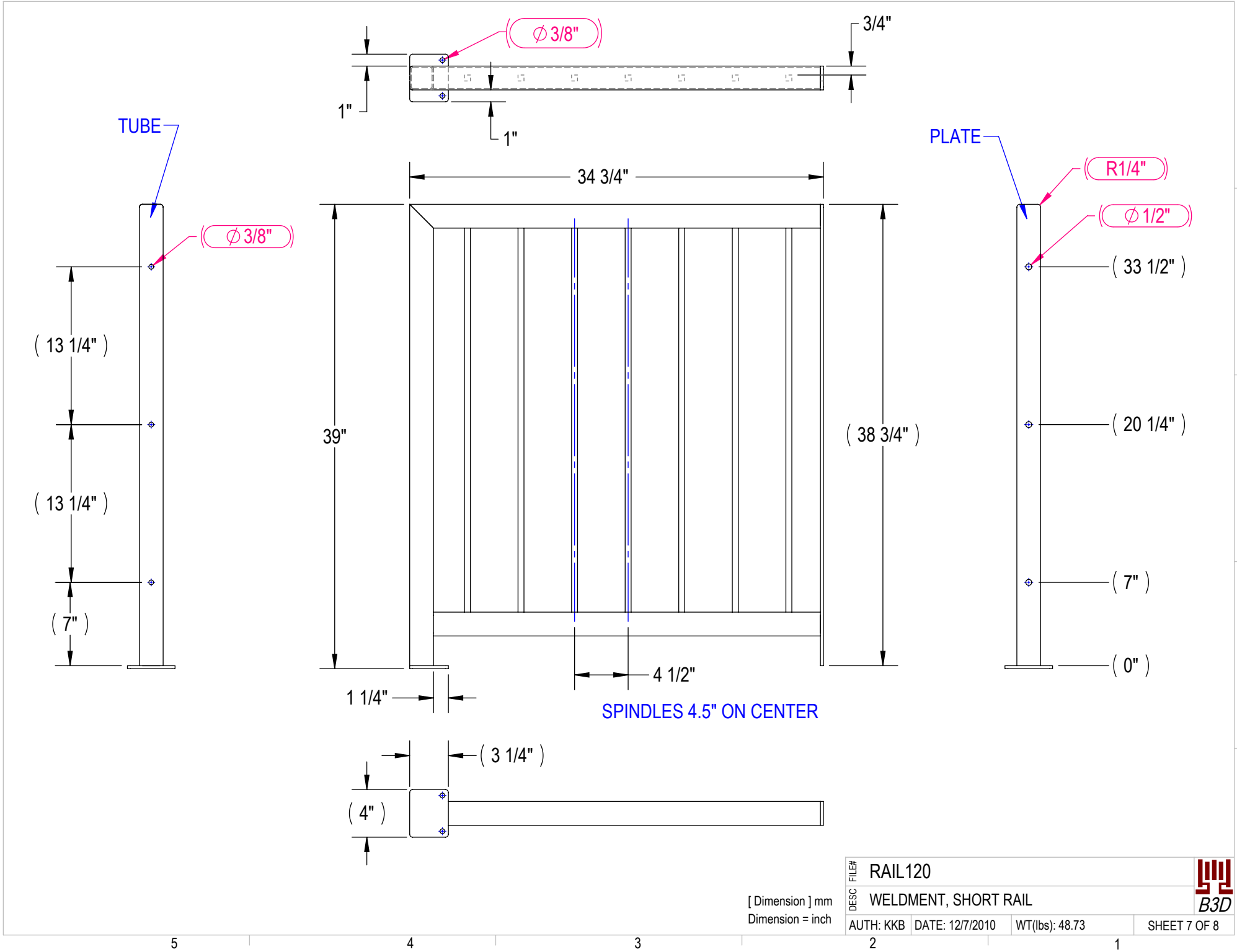

ALL PICKETS, BOTH ENDS

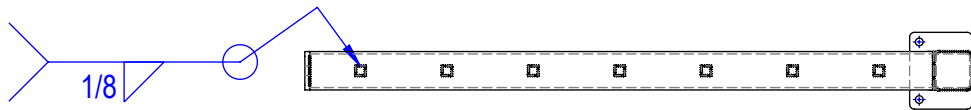

ROOM FOR RATCHET WRENCH TO LAG SCREW TO WALL

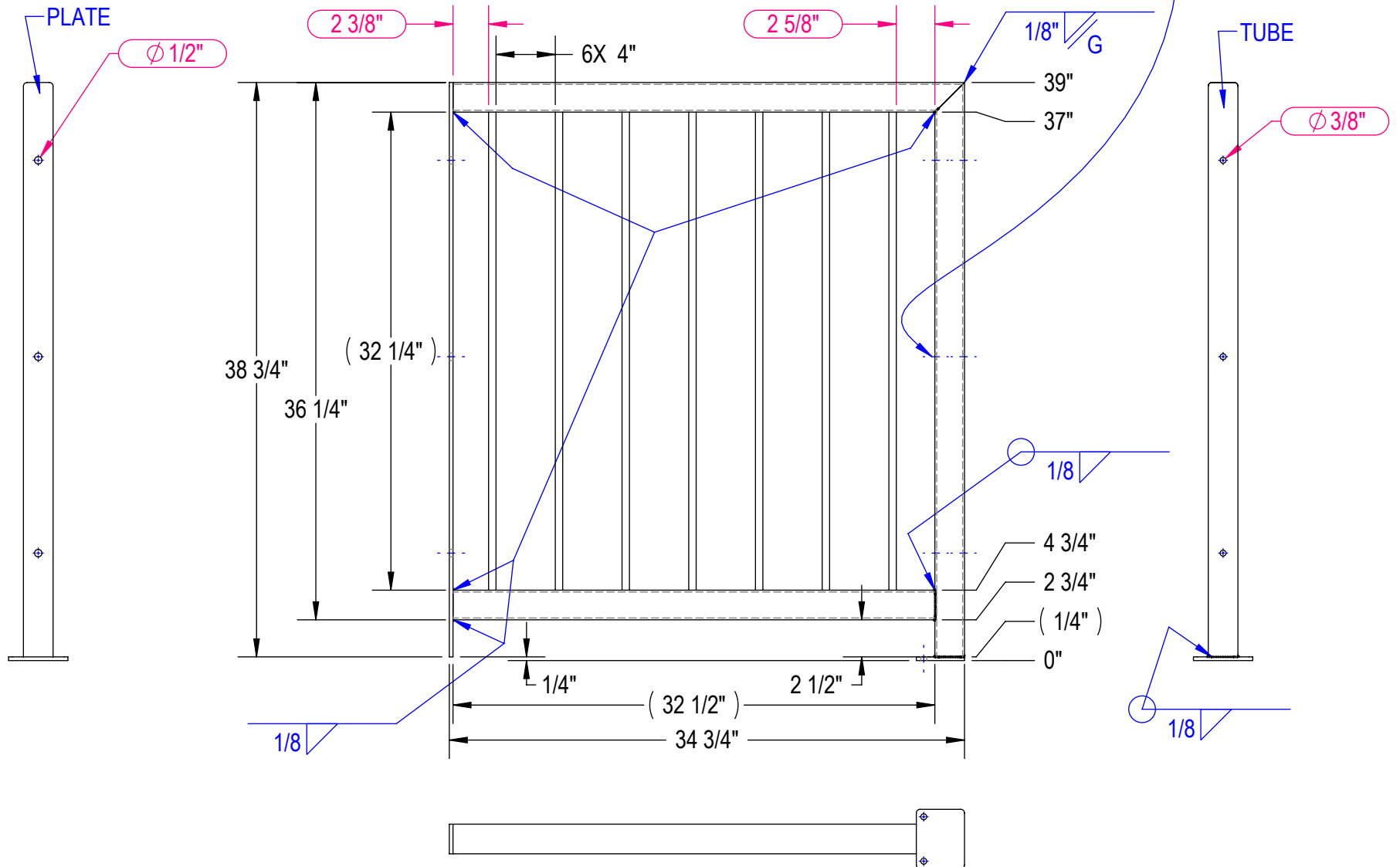

[Dimension] mm
Dimension = inch

FILE#	RAIL120		
DESC	WELDMENT, SHORT RAIL		
AUTH: KKB	DATE: 12/7/2010	WT(lbs): 48.73	SHEET 8 OF 8

